

HS-150IS Premium Intrinsically Safe Accelerometer

AC acceleration output via PUR Cable

Key Features

- Intrinsically Safe with European, Indiana, USA and Australian approvals
- Side entry for easy access
- For use with data collector

Industries

Building services, Pulp and Paper, Mining, Metals, Utilities, Automotive, Water, Pharmaceutical

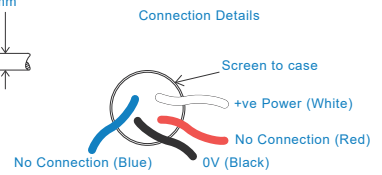
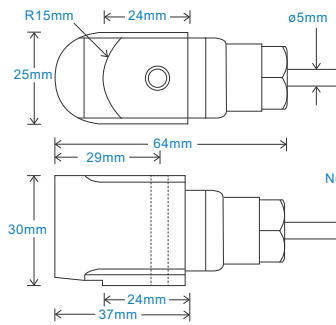
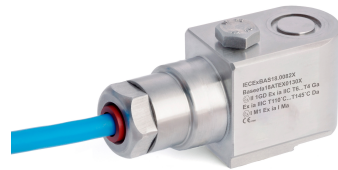

Technical Performance		Mechanical	
Mounted Base Resonance	see 'How To Order' table (nominal)	Case Material	Stainless Steel
Sensitivity	see: 'How To Order' table $\pm 10\%$ Nominal 80Hz at 22°C	Sensing Element/Construction	PZT/Shear
Frequency Response	2Hz (120cpm) to 10kHz (600kcpm) $\pm 5\%$ 1.5Hz (90cpm) to 12kHz (720kcpm) $\pm 10\%$ 0.8Hz (48cpm) to 15kHz (900kcpm) $\pm 3dB$	Mounting Torque	8Nm
Isolation	Base isolated	Mounting Bolt provided	see: 'How To Order' table x 35mm long
Range	see: 'How To Order' table	Weight	205gms (nominal) body only
Transverse Sensitivity	Less than 5%	Maximum Cable Length	See certificate
		Standard Cable Length	5 metres
		Screened Cable	PUR - length to be specified with order
		Mounting Threads	see: 'How To Order' table
		Submersible Depth	100 metres max (10 bar)

Electrical		Environmental	
Excitation Voltage:	18-30Volts DC	Operating Temperature Range	see: attached certification details
Electrical Noise	0.1mg max	Sealing	IP68
Current Range	0.5mA to 8mA	Maximum Shock	5000g
Bias Voltage	10 - 12 Volts DC	EMC	EN61326-1:2013
Settling Time	2 seconds		
Output Impedance	200 Ohms max.		
Case Isolation	$>10^8$ Ohms at 500 Volts		

Typical Frequency Response (at 100mV/g)

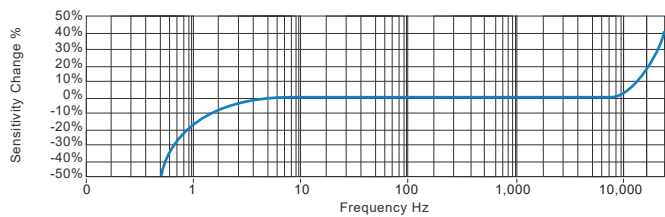

Applications

Fans, Motors, Pumps, Compressors, Centrifuges, Conveyors, Air Handlers, Gearboxes, Rolls, Dryers, Presses, Cooling, VAC, Spindles, Machine Tooling, Process Equipment

Vibration sensor should be firmly fixed to a flat surface (spot face surface may be needed to be produced and cable anchored to sensor body.)

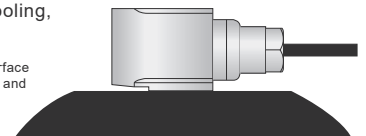

Certifications



This product is certified in accordance with
UL 60079-0, 6th Ed. Rev. July 26, 2013
UL 60079-11, 6th Ed. Rev. September 6, 2013
CAN/CSA C22.2 No. 60079-0:15 Rev. October 2015
CAN/CSA C22.2 No. 60079-11:14
UL 913, 8th Ed. Rev. October 16, 2015



T: 150 210 98804
www.hansfordsensors.com.cn
 汉施弗德传感器（上海）有限公司



HS-150IS Premium Intrinsically Safe Accelerometer

AC acceleration output via PUR cable

Intrinsically Safe Requirements

Sensor Maximum Cable Length	Up to 92 metres	Certified Temperature Range	Ex ia IIC T6 Ga (-55°C ≤ Ta ≤ +57°C) (Gas) Ex ia IIC T4 Ga (-55°C ≤ Ta ≤ +103°C) (Gas)
Certificate details: Group I	IECEX 18.0082X Baseefa18ATEX0130X ⓈI M 1 Ex ia I Ma		Ex ia IIIC T110°C Da (-55°C ≤ Ta ≤ +57°C) (Dust) Ex ia IIIC T135°C Da (-55°C ≤ Ta ≤ +70°C) (Dust) Ex ia IIIC T145°C Da (-55°C ≤ Ta ≤ +92°C) (Dust) Ex ia I Ma (-55°C ≤ Ta ≤ +103°C) (Mining)
Certificate details: Group II and III	IECEX 18.0082X Baseefa18ATEX0130X ⓈII 1GD Ex ia IIC T6..T4 Ga Ex ia IIIC T110°C..T145 Da	Australian Approval Group I	IECEX ExTC 18.0032X Ex ia I Ma (-55°C ≤ Ta ≤ +104°C)
Terminal Parameters 10m of cable	Ui = 28V, li = 93mA, Pi = 0.65W Ci = 5.0nF Li = 7.2µH	US/Canada Approvals	Certificate No. SGSNA/19/BAS/00005 CI I, II, III, Div 1, 2 Gr A-G T* CI I Zn 0 AEx ia IIC T6...T4 Ga CI II Zn 20 AEx ia IIIC T110°C...T145°C Da CI II Zn 20 AEx ia IIIB T110°C...T145°C Da Ex ia IIC T6...T4 Ga Ex ia IIIC T110°C...T145°C
Terminal Parameters 92m of cable	Ui = 28V, li = 93mA, Pi = 0.65W Ci = 35.9nF Li = 66µH	Control Drawing	M06-083-A Overbraided Cable M06-084-A PUR Cable M06-085-A Silicone Cable M06-086-A FR PUR Cable M06-087-A Various Cables (HS-150IT Only)
500V Isolation	Units Will Pass A 500V Isolation Test	Barrier	1 x Pepperl + Fuchs Galvanic Isolator KFD2-VR4-Ex1.26 (BAS02ATEX7206) 1 x MTL Zener Barrier MTL7728+ (BAS01ATEX7217) or Pepperl + Fuchs Zener Barrier Z728 (BAS01ATEX7005) or any other barrier that conforms with the terminal parameters
Standards Applied to Product	EN IEC 60079-0:2018 EN 60079-11:2012		

Special conditions of use: When a sensor is supplied with integral cable, this must be terminated in an enclosure providing at least degree of protection IP20.

Note: If the equipment is to be used in unusual environments or aggressive substances are likely to be encountered, contact the manufacturer to discuss suitability.

How To Order

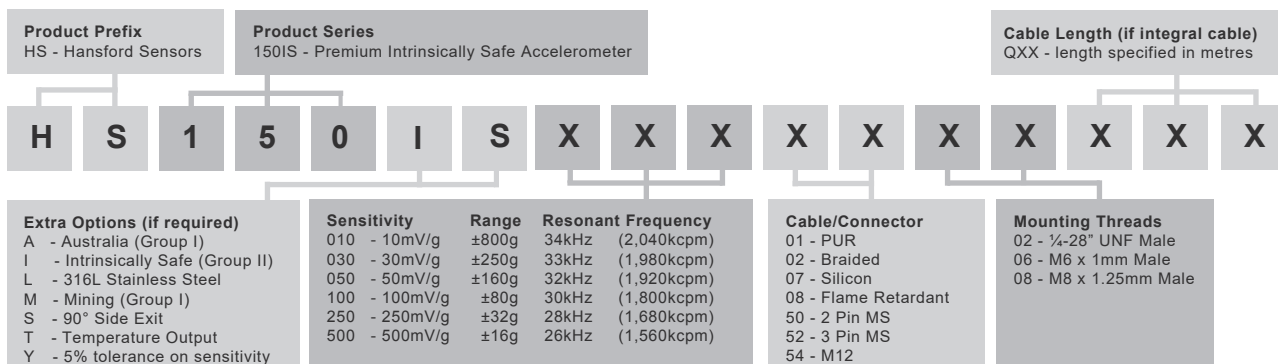

T: 150 210 98804

www.hansfordsensors.com.cn

汉施弗德传感器（上海）有限公司

