

# HS-100I Intrinsically Safe Accelerometer

## AC acceleration output via Silicon Cable

### Key Features

- Intrinsically Safe with European, USA, South African, Indian, Korean and Australian approvals
- For use with data collector

### Industries

Building services, Pulp and Paper, Mining, Metals, Utilities, Automotive, Water, Pharmaceutical

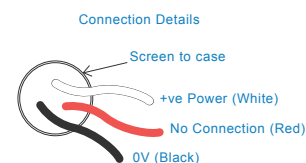
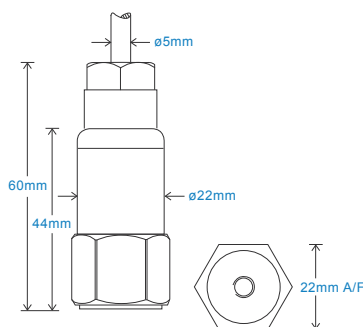

### Technical Performance

Mounted Base Resonance	see 'How To Order' table (nominal)
Sensitivity	see: 'How To Order' table $\pm 10\%$ Nominal 80Hz at 22°C
Frequency Response	2Hz (120cpm) to 10kHz (600kcpm) $\pm 5\%$ 1.5Hz (90cpm) to 12kHz (720kcpm) $\pm 10\%$ 0.8Hz (48cpm) to 15kHz (900kcpm) $\pm 3dB$
Isolation	Base isolated
Range	see: 'How To Order' table
Transverse Sensitivity	Less than 5%

### Mechanical

Case Material	Stainless Steel
Sensing Element/Construction	PZT/Compression
Mounting Torque	8Nm
Weight	106gms (nominal) body only
Maximum Cable Length	1000 metres
Standard Cable Length	5 metres
Screened Cable	Silicon - length to be specified with order
Mounting Threads	see: 'How To Order' table
Submersible Depth	100 metres max (10 bar)

### Electrical

Excitation Voltage:	18-30Volts DC
Electrical Noise	0.1mg max
Current Range	0.5mA to 8mA
Bias Voltage	10 - 12 Volts DC
Settling Time	2 seconds
Output Impedance	200 Ohms max.
Case Isolation	$>10^8$ Ohms at 500 Volts

### Environmental

Operating Temperature Range	see: attached certification details
Sealing	IP68
Maximum Shock	5000g
EMC	EN61326-1:2013

### Typical Frequency Response (at 100mV/g)

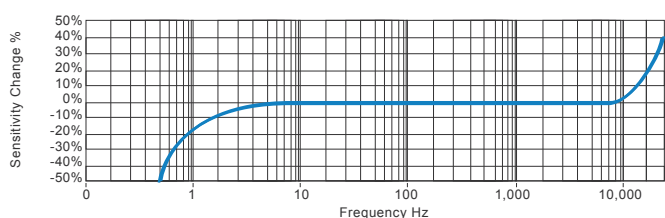

### Applications

Fans, Motors, Pumps, Compressors, Centrifuges, Conveyors, Air Handlers, Gearboxes, Rolls, Dryers, Presses, Cooling, VAC, Spindles, Machine Tooling, Process Equipment

Vibration sensor should be firmly fixed to a flat surface (spot face surface may be needed to be produced and cable anchored to sensor body.)

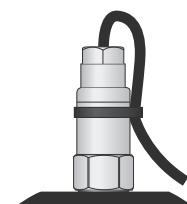

### Certifications



This product is certified in accordance with  
**UL 913, 8th Ed. Rev. December 6, 2013**  
**CAN/CSA C22.2 No. 157-92 (R2012) +Upd1 +Upd2**



T: 150 210 98804  
[www.hansfordsensors.com.cn](http://www.hansfordsensors.com.cn)  
 汉施弗德传感器（上海）有限公司



# HS-100I Intrinsically Safe Accelerometer

## AC acceleration output via Silicon Cable

### Intrinsically Safe Requirements

Maximum Cable Length	See <a href="http://www.hansfordsensors.com.cn">www.hansfordsensors.com.cn</a> see attached system drawing	Australia Approval Group I	IECEX ITA 11.0013X Ex ia I Ma (-55°C ≤ Ta ≤ +110°C)
Certificate details: Group I	IECEX BAS07.0037X Baseefa07ATEX0149X ⓈI M1 Ex ia I Ma (-55°C ≤ Ta ≤ +110°C)	US/Canada Approvals Class I, II, III, Division 1, 2, Groups A - G, T4, -55°C to +110°C, IP65 Class I, Zone 0, AEx, ia, IIC, T4, Ga, -55°C to +110°C Zone 20, AEx, ia, IIIC, T130°C, IP65, Da, -55°C to +110°C	Certificate No. USTC/15/FAI/01350
Certificate details: Group II (ignition temperature 130°C)	IECEX BAS07.0035X Baseefa07ATEX0144X ⓈII 1GD Ex ia IIC T4 Ga Ex ia IIIC T130°C IP65 Da (-55°C ≤ Ta ≤ +110°C)	Class I, II, III, Division 1, 2, Groups A - G, T6, -55°C to +60°C Class I, Zone 0, AEx, ia, IIC, T6, Ga, -55°C to +60°C Zone 20, AEx, ia, IIIC, T80°C, IP65, DA, -55°C to +60°C	Certificate No. MASC S/16-0231X Group II (As Baseefa/ATEX) MASC M/16-0230X Group I (As Baseefa/ATEX)
Certificate details: Group II (ignition temperature 80°C)	IECEX BAS07.0035X Baseefa07ATEX0144X ⓈII 1GD Ex ia IIC T6 Ga Ex ia IIIC T80°C IP65 Da (-55°C ≤ Ta ≤ +60°C)	South African Approval Korean Approval Group II	Certificate No. MASC S/16-0231X Group I (As Baseefa/ATEX) Certificate No 19-AV4BO-0048X Ex ia IIC T6/T4 T6 -55°C < Ta < +60°C T4 -55°C < Ta < +110°C
Accelerometer System Certificate	Baseefa07Y0145 Ex ia IIC T6 (-55°C ≤ Ta ≤ +60°C) Ex ia IIC T4 (-55°C ≤ Ta ≤ +110°C) On request - consult Sales Office	Terminal Parameters V <sup>U</sup> = 28V, I <sup>U</sup> = 93mA, P <sup>U</sup> = 0.65W C <sup>i</sup> = 83nf Li/Ri = 15.4μF/Ohm	Ui = 28V, Ii = 93mA, Pi = 0.65W Ci = 9.9nf Li = 7μF or Li/Ri = 15.4μF/Ohm Ui = 28V, Ii = 93mA, Pi = 0.65W Ci = 83nf Li/Ri = 15.4μF/Ohm
Terminal Parameters	Ui = 28V, Ii = 93mA, Pi = 0.65W Ci = 83nf Li/Ri = 15.4μF/Ohm	System Connections	see attached system drawings
500V Isolation	Units Will Pass A 500V Isolation Test	Barrier	1 x Pepperl + Fuchs Galvanic Isolator KFD2-VR4-Ex1.26 (BAS02ATEX7206) see attached system drawings
Certified Temperature Range	Ex ia IIC T6 Ga (-55°C ≤ Ta ≤ +60°C) (Gas) Ex ia IIIC T80°C IP65 Da (-55°C ≤ Ta ≤ +60°C) (Dust) Ex ia IIC T4 Ga (-55°C ≤ Ta ≤ +110°C) (Gas)* Ex ia IIIC T130°C IP65 Da (-55°C ≤ Ta ≤ +110°C) (Dust)* Ex ia I Ma (-55°C ≤ Ta ≤ +110°C) (Mining) *On request - consult Sales Office	1 x MTL Zener Barrier MTL7728+ (BAS01ATEX7217) or Pepperl + Fuchs Zener Barrier Z728 (BAS01ATEX7005) or any other barrier that conforms to system drawings on website	
		Notes: Special conditions of safe use for Group I & II. The free end of the cable on the integral cable version of the apparatus must be terminated in an appropriate dust-proof enclosure.	

### Intrinsically Safe Requirements for IC3 Variations

HS-100IC3 Variation is certified as Category 3 equipment. These sensors are only certified for use within Zones 2.	Certified Temperature Range	Ex ic IIC T4 Gc (-55°C ≤ Ta ≤ +110°C)
	Terminal Parameters	Ui = 25.2V, Ii = 146mA, Pi = 0.92W Ci = 83nf Li 66μH
Certificate Details: Group II (ignition temperature 130°C)	IECEX BAS17.0054X Baseefa7ATEX0069X ⓈII 3G Ex ic IIC T4 Gc (-55°C ≤ Ta ≤ +110°C)	500V Isolation Units will pass a 500V Isolation Test Special Conditions of Use: The Ci and Li parameters listed on the equipment certificate must be taken into account when connecting this equipment.

### How To Order

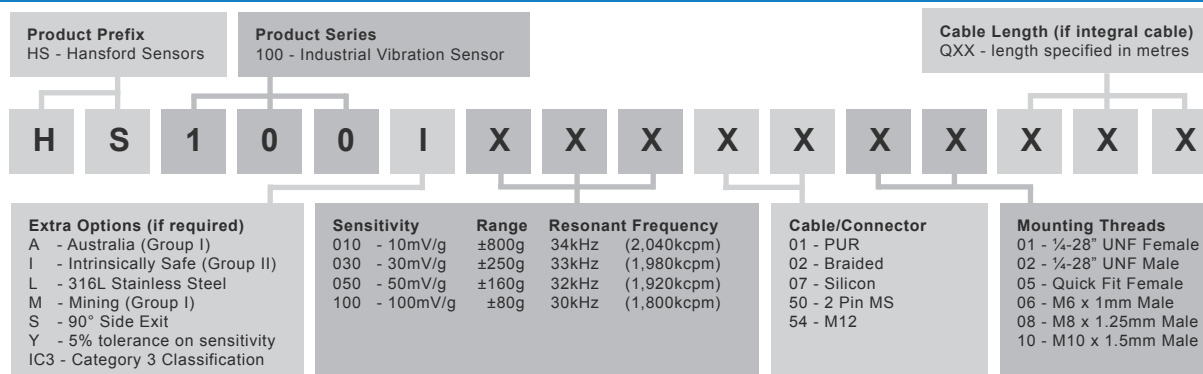

Non-hazardous area apparatus which is unspecified except that it must not be supplied from nor contain under normal or abnormal conditions, a source of potential with respect to earth in excess of 250 volts DC. under normal conditions the potential at the connections to the galvanic isolator must not exceed 40 volts DC.

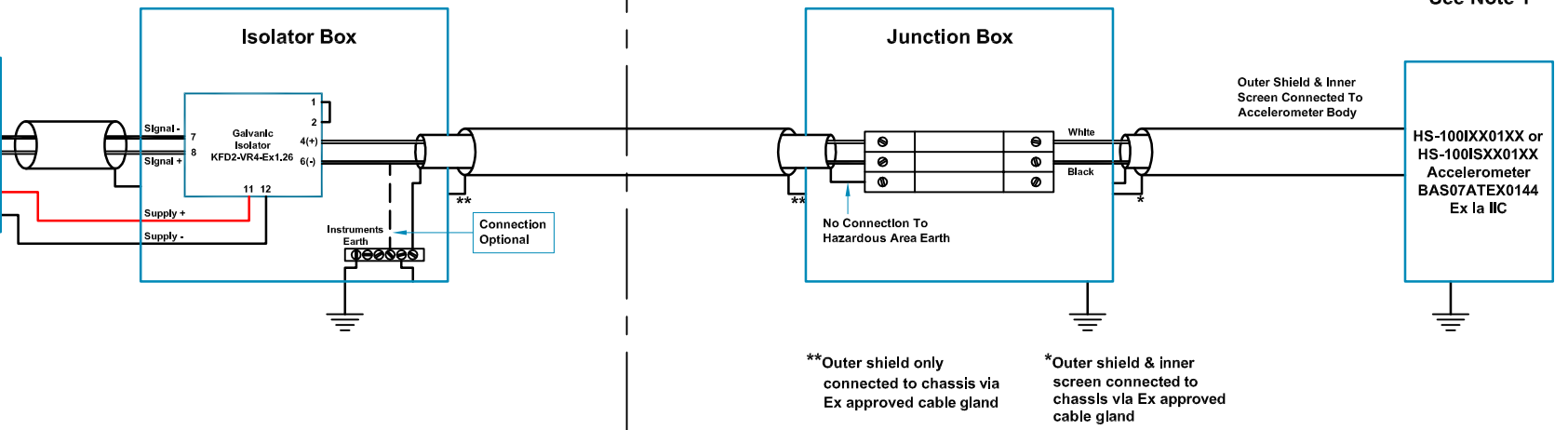

**Table 1: Cable Parameters For Additional Cable Lengths**

Accelerometer With Integral Cable Length ≤ 10m		
Group	Capacitance μF	L/R Ratio μH/Ω
IIC	0.086	46
IIB	0.730	172
IIA	2.470	363
Accelerometer With Integral Cable Length ≤ 50m		
Group	Capacitance μF	L/R Ratio μH/Ω
IIC	0.051	46
IIB	0.695	172
IIA	2.435	363
Accelerometer With Integral Cable Length ≤ 92m		
Group	Capacitance μF	L/R Ratio μH/Ω
IIC	0.013	46
IIB	0.657	172
IIA	2.397	363

**Hansford Sensors Ltd**

HS-100I or HS-100IS  
Accelerometer System  
Baseefa07Y0145/1  
Ex ia IIC T4 (-55°C ≤ Ta ≤ +110°C) or  
Ex ia IIC T6 (-55°C ≤ Ta ≤ +60°C)

**Notes:**

- The capacitance and inductance, to resistance ratio (L/R) of hazardous area cable, must not exceed the values shown in Table 1.
- The Installer is to perform a risk assessment in accordance with clause 10 of EN 60079-25 and install lightning protection arrestors as deemed necessary.

Rev No	DRF No	Date Drg	Drg By	Appd By	Material: N/A	<p><b>Hansford Sensors</b> Excellence in Vibration Monitoring</p> <p>Hansford Sensors Ltd Artisan, Hillbottom Rd Sands Industrial Estate High Wycombe Bucks HP12 4HJ</p>	<p>Do Not Scale</p>	Description: System Connections For HS-100I & HS-100IS Group II Accelerometers With Armoured Cable F.U.W. Galvanic Isolation	
A	Release	15/06/07	MJS	CMH	<p>Tolerances Unless Stated</p> <p>0 or 0.0 ±0.5</p> <p>0.00 ±0.15</p> <p>Angle ±5°</p> <p>1.6/∇ Finish All Over Threads g6 H6</p>			<p>All Dimensions In mm Unless Otherwise Stated</p> <p><b>If In Doubt - Ask!</b></p>	Drawing No: M06-003-B
B	DFR0164	13/01/11	MJS	CMH		Scale: NTS	Form Number: QF024 Issue 1		
						Sheet: 1 of 2			

Non-hazardous area apparatus which is unspecified except that it must not be supplied from nor contain under normal or abnormal conditions, a source of potential with respect to earth in excess of 250 volts rms or 250 volts dc. under normal conditions the potential at the connections to the zener barrier must not exceed 40 volts dc.

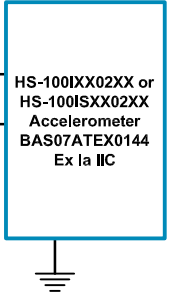
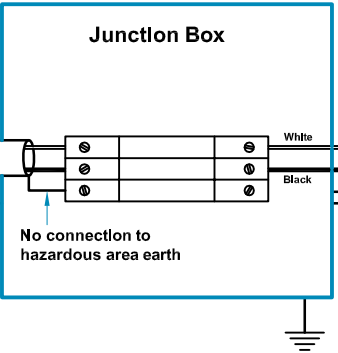
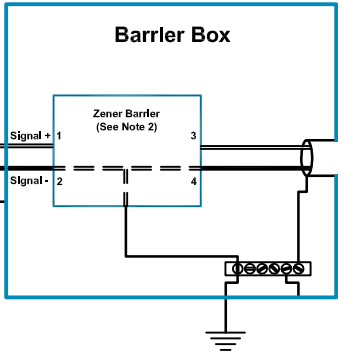

\*\*Outer shield only connected to chassis via Ex approved cable gland  
 \*Outer shield & Inner screen connected to chassis via Ex approved cable gland

**Table 1: Cable Parameters For Additional Cable Lengths**

Accelerometer With Integral Cable Length ≤ 10m		
Group	Capacitance μF	L/R Ratio μH/Ω
IIC	0.073	56
IIB	0.239	168
IIA	0.654	448
Accelerometer With Integral Cable Length ≤ 50m		
Group	Capacitance μF	L/R Ratio μH/Ω
IIC	0.038	56
IIB	0.204	168
IIA	0.619	448
Accelerometer With Integral Cable Length ≤ 92m		
Group	Capacitance μF	L/R Ratio μH/Ω
IIC	0.000	56
IIB	0.166	168
IIA	0.581	448

**Hansford Sensors Ltd**  
 HS-100I or HS-100IS  
 Accelerometer System  
 Baseefa07Y0145/1  
 Ex ia IIC T4 (-55°C ≤ Ta ≤ +110°C) or  
 Ex ia IIC T6 (-55°C ≤ Ta ≤ +60°C)

**Notes:**

- The capacitance and inductance, to resistance ratio (L/R) of hazardous area cable, must not exceed the values shown in Table 1.
- Any single zener diode safety barrier certified by an approved body to [Ex ia] IIC having the following output parameters: Uo = 28V dc, Io = 93mA dc, Po = 0.65W. e.g. MTL7728 to BAS01ATEX7217 or Pepperl + Fuchs Z728 to BAS01ATEX7005.
- The installer is to perform a risk assessment in accordance with clause 10 of EN 60079-25 and install lightning protection arrestors as deemed necessary.

Rev No	DRF No	Date Drg	Drg By	Appd By	Material: N/A
A	Release	15/06/07	MJS	CMH	Tolerances Unless Stated 0 or 0.0 ±0.5 0.00 ±0.15 Angle ±5° 1.6/ Finish All Over Threads g6 H6
B	DFR0164	13/01/11	MJS	CMH	

**Hansford Sensors**  
 Excellence in Vibration Monitoring  
 Hansford Sensors Ltd  
 Artisan, Hillbottom Rd  
 Sands Industrial Estate  
 High Wycombe  
 Bucks HP12 4HJ

Do Not Scale  
 All Dimensions In mm Unless Otherwise Stated  
**If In Doubt - Ask!**

Description: System Connections For HS-100I & HS-100IS Group II Accelerometers With Armoured Cable F.U.W. Zener Barrier  
 Drawing No: M06-003-B  
 Scale: NTS  
 Sheet: 2 of 2  
 Form Number: QF024 Issue 1